

# RAZORGAGE

POSITIONERS • SOFTWARE • SYSTEMS

## RazorGage ST WinPro



RazorGage ST with 15.5" Touch Screen & Windows 10 Pro, our most popular interface. Our Windows based software features screens for almost any purpose. Transfer files with WiFi, USB drive, or Bluetooth. Optional Autolist feature sorts cutlists and optimizes yield.

Supports most common PC peripherals including printers, bar code readers, thumb drives, and more.

Better Hardware  
Better Software  
Better Buy RazorGage



Ames, Iowa, U.S.A.  
[www.razorgage.com](http://www.razorgage.com)

# Better Hardware

**The RazorGage Premise:** A programmable saw stop only benefits your business if you can trust it to position accurately every day.

**Fact:** Since most saw stops calculate stop position based on motor rotation, drive component precision is crucial to long term accuracy.

**Conclusion:** Drive component quality directly affects return on investment.

Planetary gears for accuracy.

The RazorGage positioning carriage mounts on two circulating ball bearing blocks sliding on a hardened & precision ground steel rail.

5-year belt warranty

RazorGage drive pulley is machined to match the belt tooth profile to eliminate backlash. A standard drive pulley has 1/64" of backlash built in by design! Our 2" pulley is also much larger diameter to help eliminate stretching.

Small 1" pulley diameter

## Competitor

Spur gear speed reduction design prone to backlash.

Plastic friction bearing surfaces.

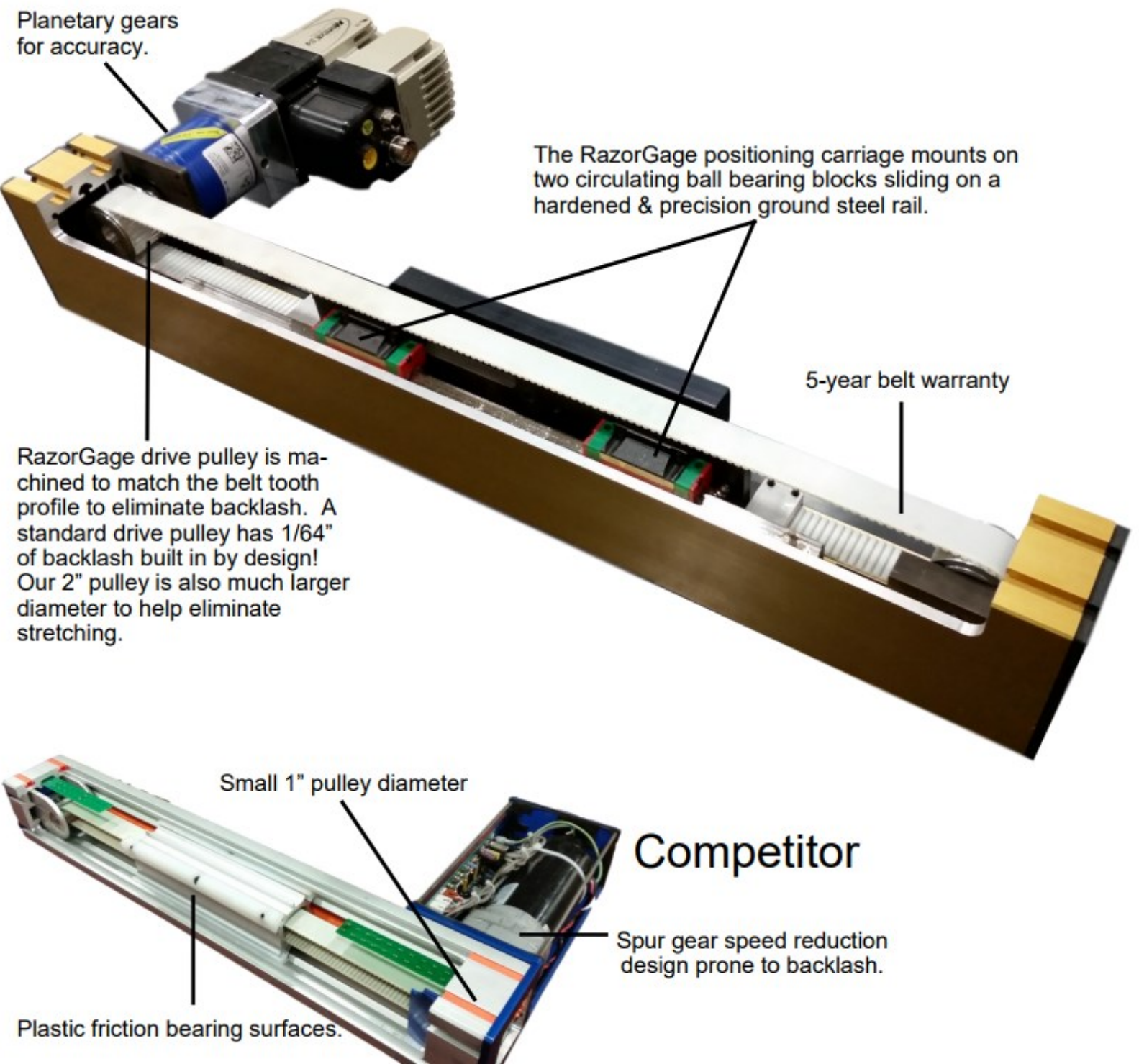

# Better Software

RazorGage is powered by Microsoft Windows so networking is no different than any other PC in your office, home, or shop. Since the RazorGage software is based on a rapid development platform, it is constantly evolving to meet the needs of our customers and can be easily customized.

**No menus to memorize.** Operation is obvious. Setup and calibration functions are just a keystroke away.

**Fraction Keys** minimize keystrokes reducing human error. Only 3 strokes to move to a position like 39 -15/32.

**Infinite Offsets with picture buttons.**

**Stores 1000's of programs**

And many more functions too numerous to explain in this flier. The RazorGage software includes pages of Presets, the Work Order Screen for simple downloading, the AutoPusher Screen for defining and running cut patterns, and the Batch Screen for defining and running same length parts from specific stock lengths. Our software is always evolving and we are happy to customize. Download a free demo version of our software at [www.razorgage.com](http://www.razorgage.com)



For details on the RazorGage software features, view the tutorial videos on our YouTube Channel accessible from [www.razorgage.com](http://www.razorgage.com).

## Autolist Defecting & Optimizing Option

**Download your cutlist.** The RazorGage Autolist Software displays your parts grouped according to your criteria. Just touch a line item and the RazorGage moves to position. Pressing the PART CUT button decrements QTY. Items are crossed off when the QTY reaches zero. Enter available clear length for an optimized solution. Use as a pusher or a stop. Include the Tool Safe Sensor to provide semi-automatic operation.

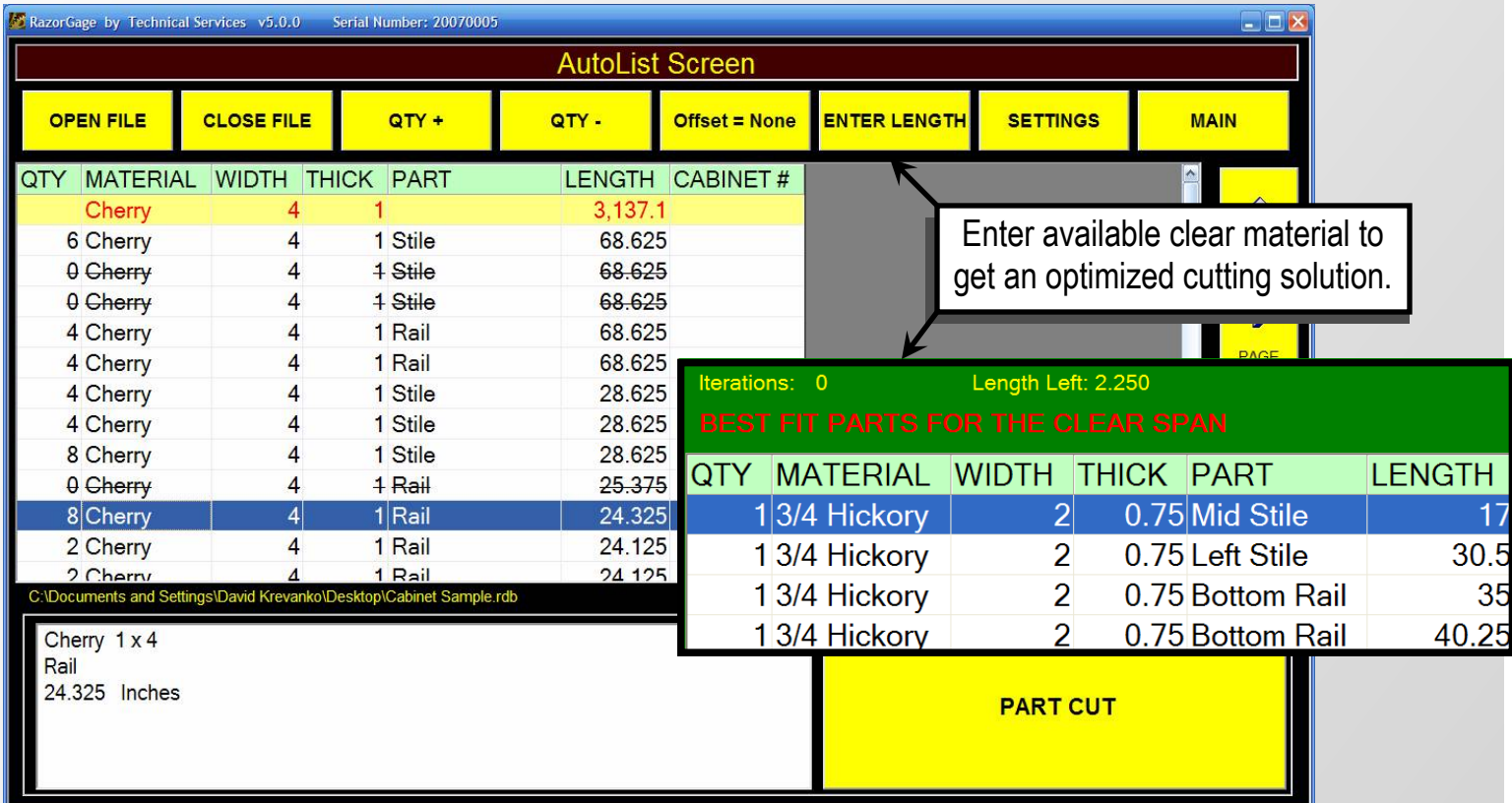

For detailed information, videos, & manuals, visit [www.razorgage.com](http://www.razorgage.com)

# RazorGage ST Specifications

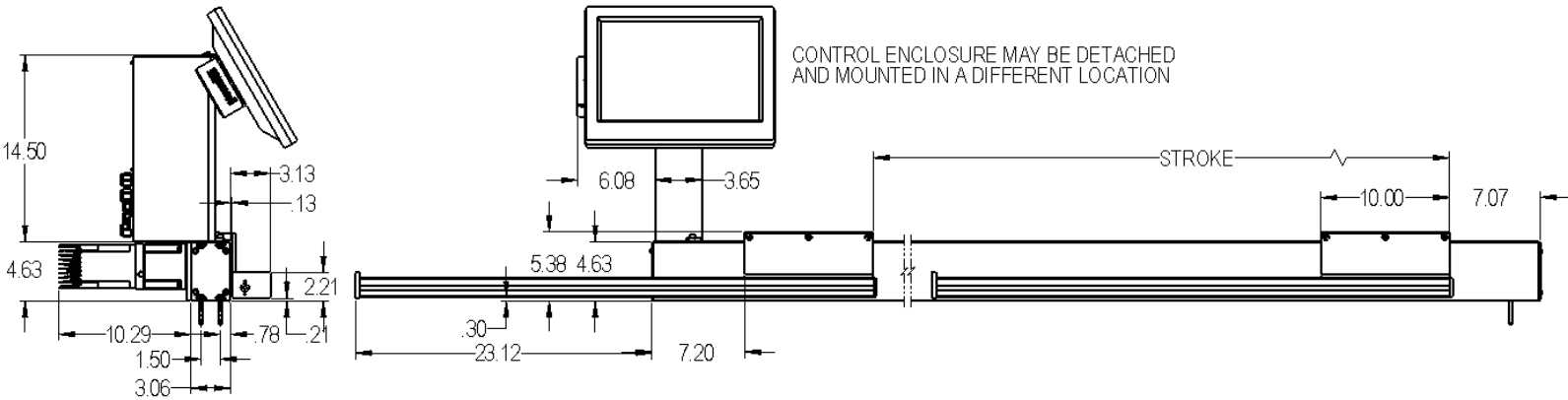

## Common Options & Accessories

- Label Printer
- Gang Stop
- Miter Stop
- Ethernet Port (Standard on Tower PC)
- WiFi (Optional on Tower PC)
- Steel Fence Facing
- Infeed/Outfeed Table with Solid PVC Top
- Roller Table with Steel, PVC or Polyurethane Rollers
- Remote Serial Control
- Position via Barcode

## Technical Details

- Accuracy:  $\pm .004$ " over 12 feet if calibrated with a capable measuring device.
- Repeatability: 0015"
- Push Force: 200 lb at 10 ips
- Max Speed: 40 ips
- Power Req'd: 120 VAC / 10 Amps
- Interface: 15.5" Touchscreen or 21" Touchscreen with Optional Tower PC
- Networking: Wifi or Ethernet (Optional)
- Operating System: Windows 10 Pro
- Max Ambient Temp: 104° F
- Available in 4~60 Foot Stroke

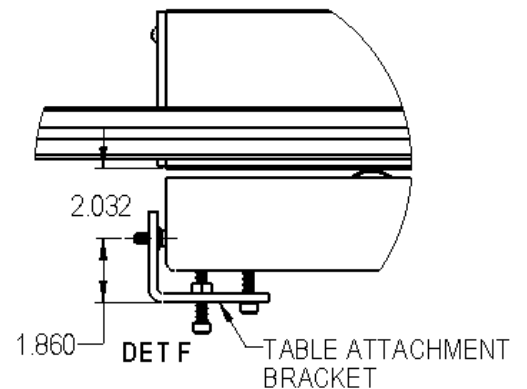
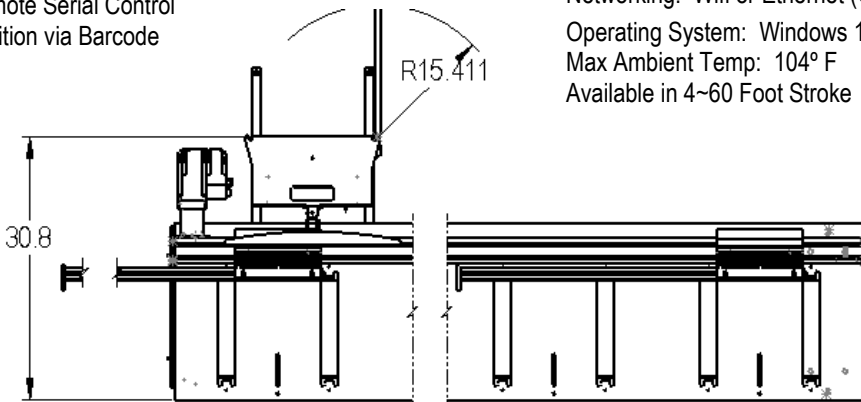

This view shows the Tower PC option as well as the table option. Table height is the same with either solid top or rollers.

