

REVISIONS				
ZONE	REV	DESCRIPTION	DATE	APPROVED
ALL	0	ORIGINAL REVISION		

# MOUNTING A: RAZORGAGE FLUSH AGAINST BACK EDGE WITH SPACE IN FRONT OF ROLLERS

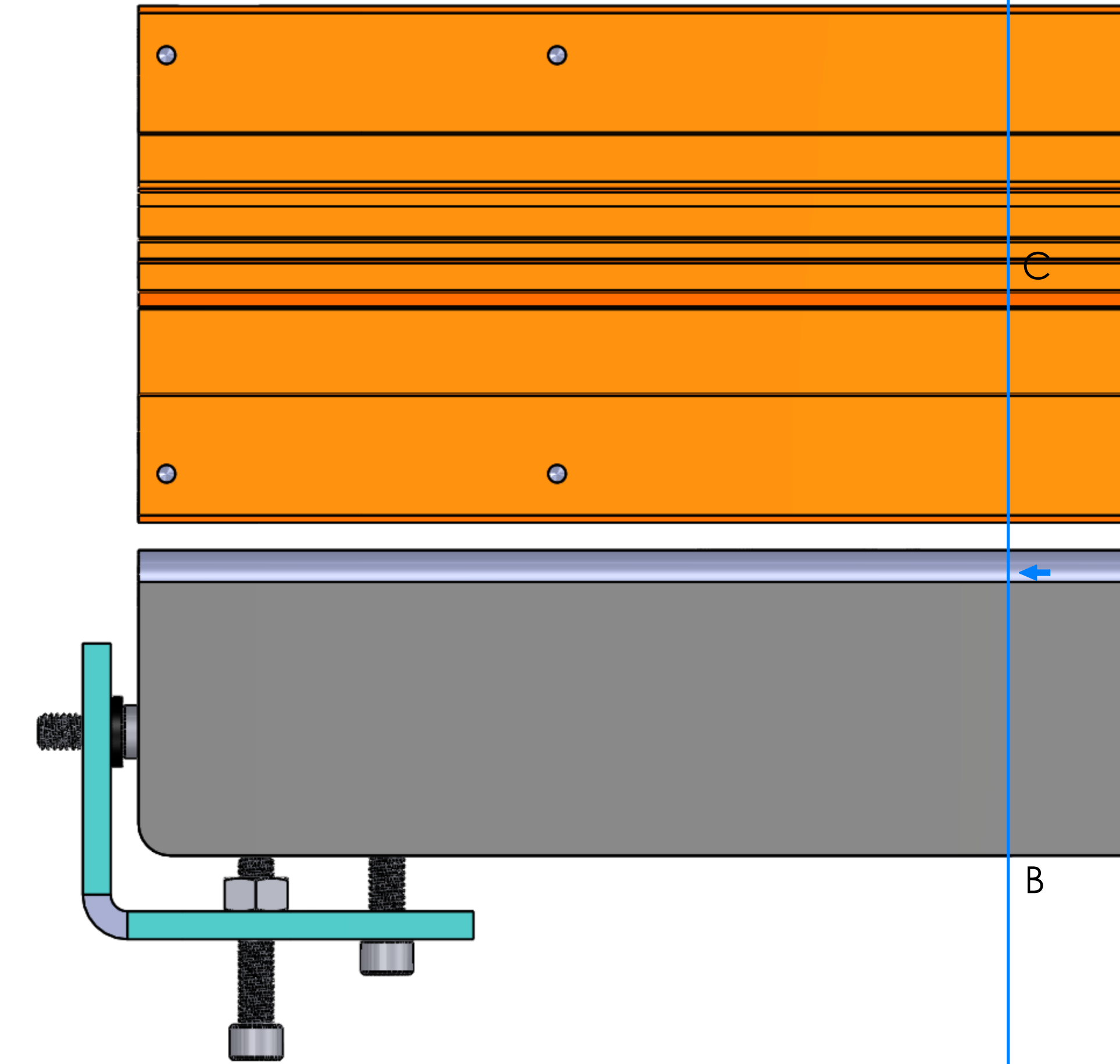
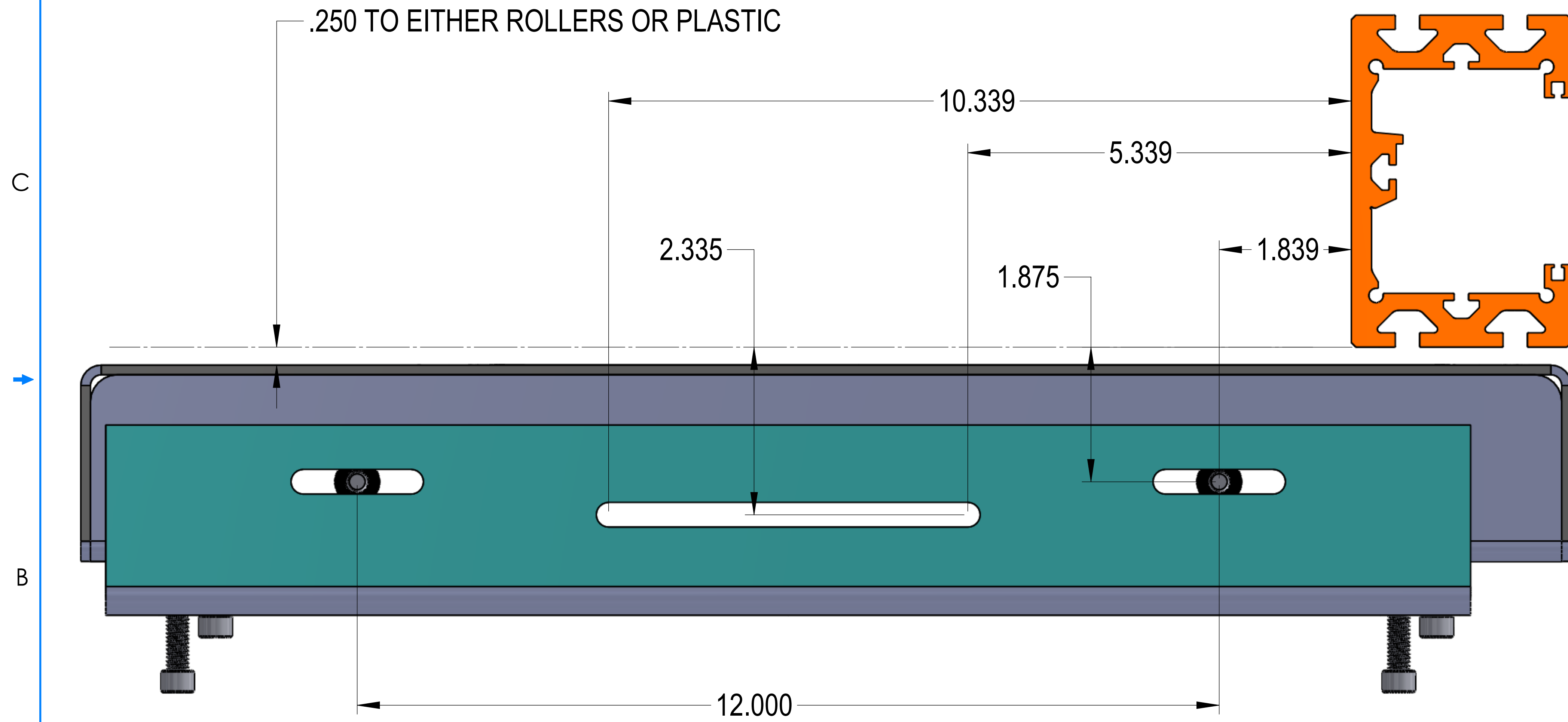
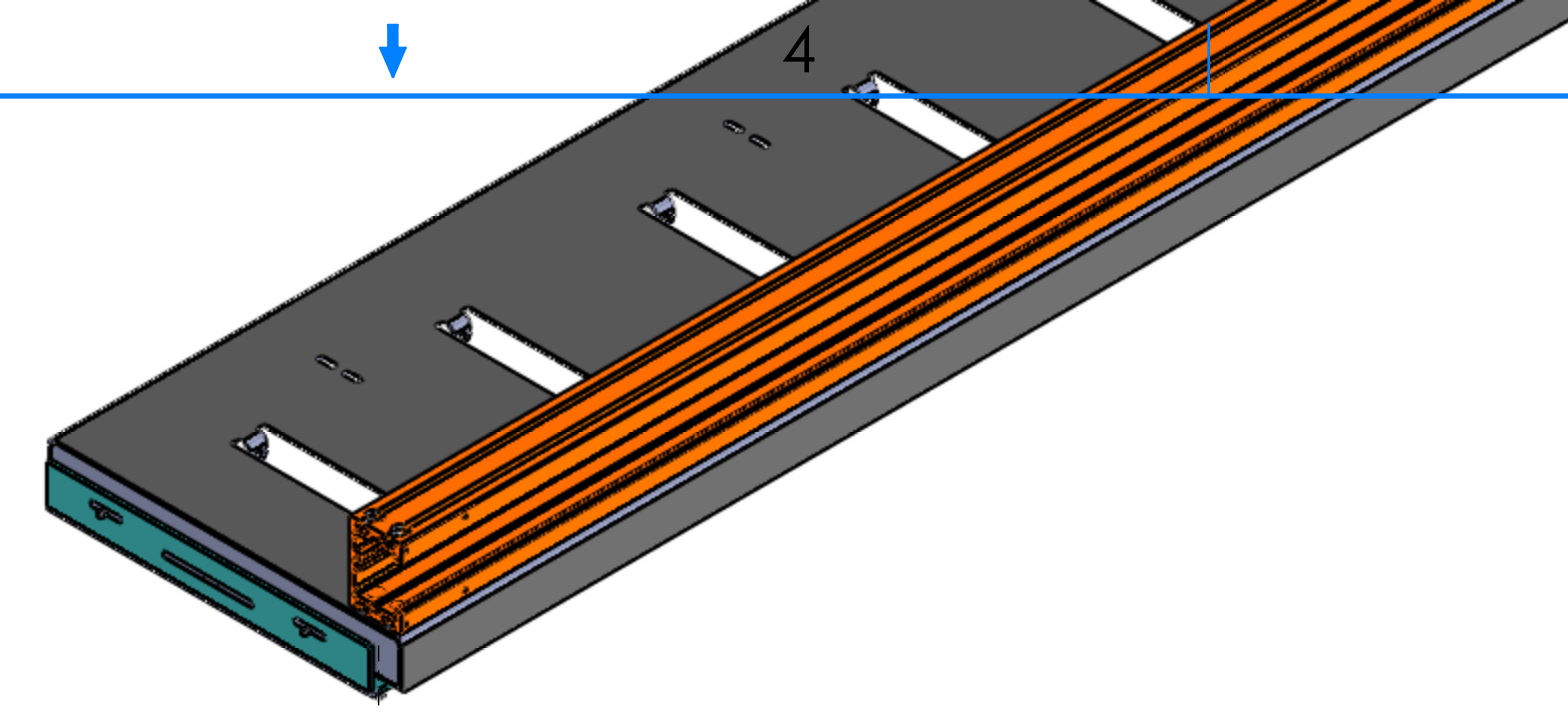

<b>STANDARD NOTES:</b> TOLERANCES UNLESS OTHERWISE SPECIFIED FRACTIONAL ± 1/16 X . XX ± .01 X . XXX ± .005 ANGLES ± 1°  BREAK ALL SHARP EDGES INTERPRET DRAWING PER ASME Y14.5 -1994	APPROVED	DATE	<b>TECHNICAL SERVICES INC.</b> CUSTOM AUTOMATION FOR INDUSTRY AMES, IA  <b>RAZORGAGE TABLE MOUNTING A</b>	
	DR BY HOSHOR	2/3/11		
	RESP ENG			
	CUSTOMER			
	SIZE B	FSCM NO.	DWG NO.	REV 1
	SCALE 1:2	WT	SHEET 1	