

# RAZOROPTIMAL OPTIMIZING SAW



## CYCLONE

## BETTER BY DESIGN

Our optimizing saw systems are built to provide durable, easy-to-operate cutting systems that are powerful, safe and can improve operating efficiencies while reducing waste.



## POCKET HOLE

RazorOptimal Pocket Hole is the only crayon defecting, optimizing saw that drills pocket holes and scribes face frame layout lines, all in one operation!



[WWW.RAZORGAGE.COM](http://WWW.RAZORGAGE.COM)

515-232-3188 | [Sales@RazorGage.com](mailto:Sales@RazorGage.com)

**RAZORGAGE**

# RAZOROPTIMAL

*Automatic Optimizing Saw Systems*

The RazorOptimal is a programmable saw system that is full of options and power that will deliver what you are looking for.

The operator simply imports premade cutlists or customizes cut settings using the optimizing saw software and marks any defects in the materials. The automated saw fence system does the rest!

This industrial saw system scans the material for defects, optimizes remaining parts to fit into the defect-free areas, automatically advances, cuts lineal stock and prints the part information directly on your material. The optimizing saw software is designed to maximize usable space on materials so that you don't end up with unnecessary waste.



## **Cyclone**

Fitted with either a 500mm or 600 mm blade.

The RazorOptimal Optimizing Saw System is unique in that it is available with either an up-cut saw or it can be outfitted with our 18-inch down-cut precision saw, for customers wanting to automatically drill pocket holes and scribe face frame marks.

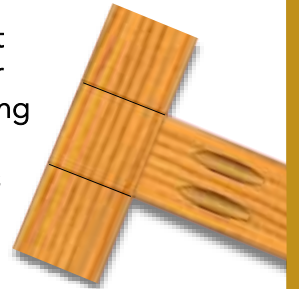

## **Pocket Hole**

Fitted with an 18" saw blade. Drills pocket hole & scribes layout face frame marks.



## FEATURES

- ◆ Windows Tower PC operation on a large, color touch-screen monitor
- ◆ Easy to use software. Store 1000's of cutlists, optimize, sort cutlists into 1000's of groups according to multiple criteria, and much more
- ◆ Optimizes between crayon marked defects
- ◆ Automatic top, left and right intelligent clamping
- ◆ Paper label printing, print directly on material or do both
- ◆ Part length accuracy varies with application but +/- .005" is possible
- ◆ Optional RazArray sorting light grid can be added to further improve operational efficiencies and reduce mistakes

From downloaded finished panel sizes, RazorOptimal turns random width boards into parts ready to glue up.

# RAZOROPTIMAL

Better Software

Our industry-leading software is powered by Microsoft Windows, so networking and file sharing is simple and seamless. Transfer files between your RazorOptimal programmable saw and any other PC in your office, home, or shop.

The RazorGage optimizing saw software is based on a rapid development platform, and it is constantly evolving to meet the needs of our customers. The software is robust and can be customized to suit a variety of operations and projects. When you buy a RazorOptimal programmable saw fence system, our onsite installer will provide hands-on training for both hardware and software. Tutorials and other reference documents are available on our website. Soon after installation, you'll be able to jump in and start using your new programmable saw to maximum effect.

## USER FRIENDLY INTERFACE



Simple touch screen menus allow for easy access to all the features of your system

## AUTOLIST SCREEN



## GROUPING SCREEN



## LABEL SETUP SCREEN

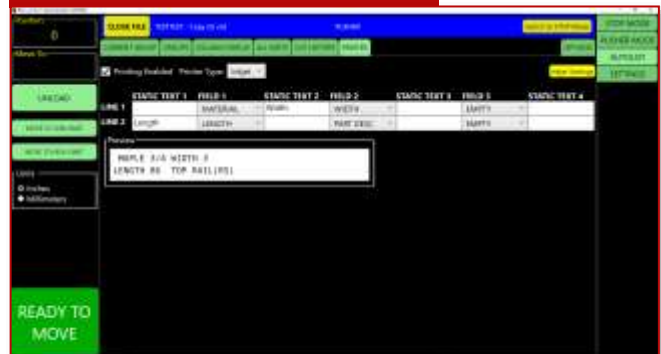

# RAZOROPTIMAL

## Options / Specifications

RazorOptimal Cyclone Specifications	
Power Requirements	Positioner - 120 VAC, 10Amp Saw (7.5hp) - 208-230VAC, 3-phase, 30 Amp -or- 460VAC, 3-phase, 20Amp
Dust Collection	Two 4" diameter (102mm) requiring 600 cfm (17m³) minimum for dry light materials. Other material may need higher velocity/pressure.
Compressed Air	Requires 80 psi (5.5 bar) at 5 cfm (0.14m³) air filtered to 2.5 microns (oil and moisture free). Use industrial air dryer, rated for cfm (CM) flow. No lubrication required for air components. Air must be lubricant free.
Motor RPM	Variable from 2200 to 3450
20" Blade for Wood	120T x 1" Bore
24" Blade for Wood	144T x 1" Bore
Push Force	200 lbs at 40 inches per second
Maximum Push Speed	50 inches per second
Stock length Capacity	Up to 16 feet

RazorOptimal Pocket Hole Specifications	
Power Requirements	Positioner - 120 VAC, 10Amp Saw (5 hp) - 208-230VAC, 3-phase, 30 Amp -or- 460VAC, 3-phase, 20Amp
Dust Collection	4" diameter (102mm) requiring 600 cfm (17m³) minimum for dry light materials. Other material may need higher velocity/pressure.
Compressed Air	Requires 80 psi (5.5 bar) at 5 cfm (0.14m³) air filtered to 2.5 microns (oil and moisture free). Use industrial air dryer, rated for cfm (CM) flow. No lubrication required for air components. Air must be lubricant free.
Motor RPM	Variable from 2200 to 3450
18" Blade for Wood	108T x 1" Bore
Push Force	200 lbs at 40 inches per second
Maximum Push Speed	50 inches per second
Stock length Capacity	Up to 16 feet
Pocket Hole Saw Maximum Material Capacity - 1.5" x 12"	

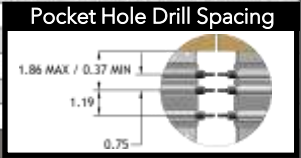

Cyclone 600 Width Capacity for Common Blades						
Material Thickness	14" Blade	16" Blade	18" Blade	500mm Blade	22" Blade	24" Blade
0.5	6.97	10.38	13.23	15.42	18.27	20.62
0.75	6.04	9.77	12.76	15.02	17.93	20.32
1	4.89	9.10	12.25	14.59	17.57	20.00
1.25	3.32	8.35	11.70	14.13	17.19	19.67
1.5		7.49	11.10	13.64	16.79	19.32

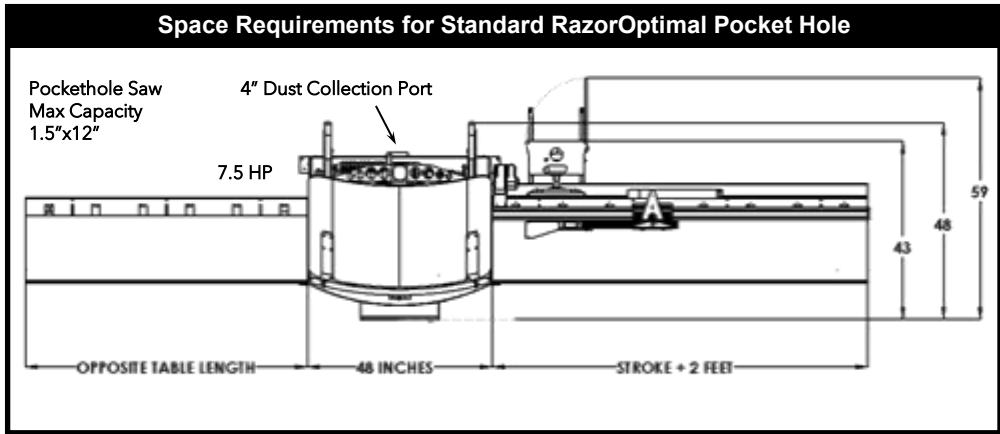
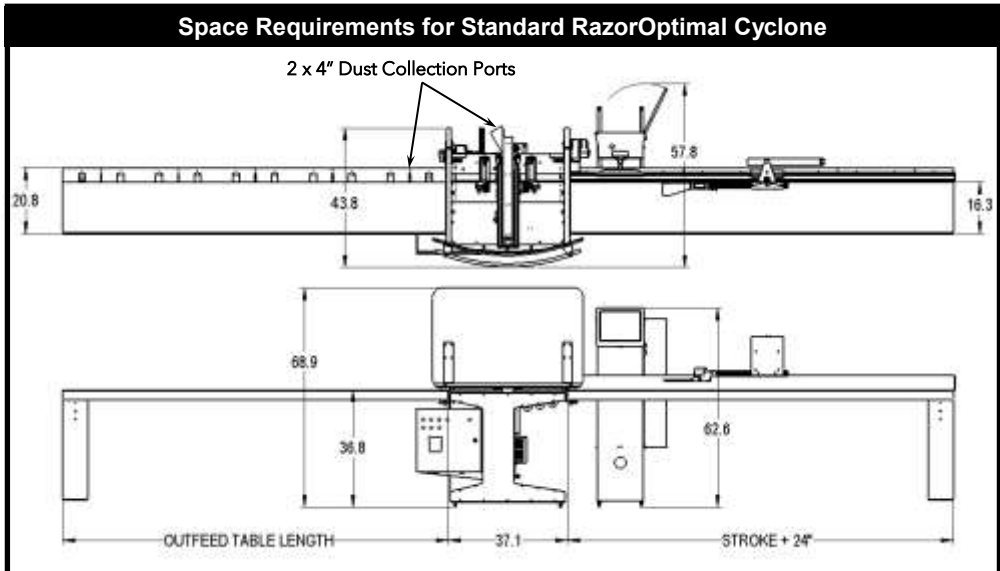

### OPTIONS

#### OUTFEED TABLE

- Height adjusts from 34.5" to 44.5"
- 1/4" Solid PVC Sheet
- Durable powder coat

#### INK JET PRINTER

Print directly on parts to keep them organized.

#### RAZARRAY SORTING ASSIST

Helps you organize parts as they come off the RazorOptimal.